

Skew Block Plane

U.S. Pat. No. 7,603,783 and U.S. Des. Pat. No. D644,904

The Veritas® Skew Block Plane combines the best features of a low-angle block plane with those of a skew rabbet plane, making it a highly versatile plane. The body has been designed to accommodate a low-angle bed with a 15° skewed blade and an adjustable fence, so that it can be used to perform many operations not possible with a regular block plane, including cutting rabbets such as around the edges of a small raised panel (i.e., fielding) and for trimming tenon cheeks. A scoring blade sits ahead of the blade and is used to reduce tear-out on cross-grain work, but can be withdrawn for work with the grain. With the fence removed, the plane can be used for general planing tasks. The compact 6³/₈" × 1³/₄" wide ductile cast iron body has a 12° bed angle and an adjustable toe that is completely enclosed by the body casting. It is available in both right- and left-hand configurations, with your choice of lapped A2, O1 or PM-V11® tool steel blade.

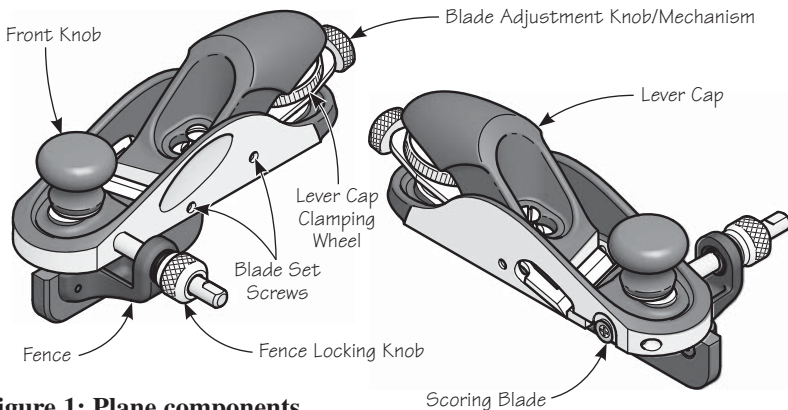

Figure 1: Plane components.

Setting the Blade for Planing Without the Fence

⚠ Caution: Be aware that the blade is sharp; careless handling can result in serious injury.

To initially set the blade, open the mouth fully, and place the plane on a flat wood surface (e.g., a scrap of stock). Lightly clamp the blade with the lever cap wheel and advance the blade until it just touches the wood.

Flip the plane to a sole-up position, then sight along the sole to ensure the blade edge is parallel to the sole and advance or retract it as required. Clamp fully (a quarter turn should be ample – **do not overclamp**) and take a test cut. If all is well, advance the three set screws on either side of the body until they just touch the blade, not to clamp it but to create a guide so that you do not have to be concerned about the blade shifting. You will quickly get accustomed to setting blade depth only by sighting along the sole, but for setting very fine shavings, you will still need to take test cuts.

Setting the Blade for Planing with the Fence

When cutting rabbets, the position of the blade relative to the plane body is critical for optimum performance. The cutting edge must be set to the correct projection to achieve the desired depth of cut and must be parallel to the sole of the plane. In addition, to ensure that it cuts right into the corner of a rabbet, it is critical that the inside (or leading) edge of the blade extend just beyond the side of the plane.

Note: The slight gap between the blade and the outer edge of the bed is due to design and manufacturing requirements; it does not affect the plane's performance.

The proper blade position relative to the side of the plane is established using the three blade set screws. First, back off the lever cap wheel just enough to free up the blade. Then, while holding the blade against the two outer set screws with your finger, adjust the two set screws until the correct blade position is attained. Remember to keep the cutting edge parallel with the sole. When all is well, adjust the third inner set screw until it just contacts the blade; again, not to clamp it, but to create a guide. Once set, the set screws will allow the blade to be adjusted for depth of cut as well as removed from the plane and then returned to its previously established position.

The blade adjustment mechanism is retained in the body by a small set screw in the back of the housing. If you need to remove the mechanism, back this set screw off until the mechanism can be removed. (It is not necessary to completely remove the set screw.) When reinstalling the mechanism, tighten the set screw only such that the mechanism cannot be removed.

Two Cautionary Notes

1. The lever cap clamping wheel has tremendous mechanical advantage. For normal use, it needs to be tightened only a quarter turn after full engagement with the blade. **Never torque it down as hard as you can or you may damage the plane.**
2. Before advancing the blade at any time, check the mouth opening to be sure you don't run the blade against the adjustable toe piece. It is a simple matter to close the mouth to the desired opening **after** you have reached the right blade projection.

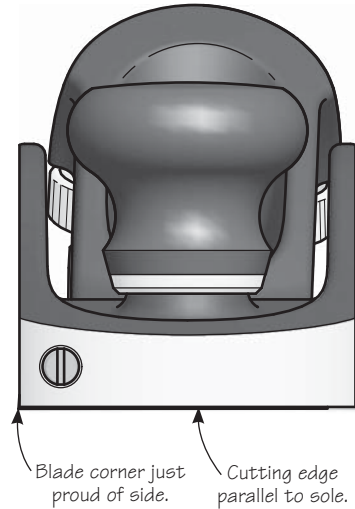

Figure 2: Blade position when using the fence.

Backlash and How To Avoid It

To eliminate the possibility of the blade shifting backward unpredictably as the backlash is taken up, the final setting should always be made with the blade being advanced by the clockwise movement of the knob. If you need to retract the blade slightly, retract it more than required, and finish by **advancing** it to its desired position. This takes up all the play in the forward direction, eliminating any shifting in use.

Mouth Adjustment

The movable toe piece enables you to quickly and accurately set the mouth opening between the blade and the toe piece to suit the task. Generally, you will want a mouth as small as will allow the shaving to escape. The reason for this is that a tight mouth supports the wood ahead of the blade, preventing tear-out.

Loosen the front knob and adjust the position of the toe by sliding the front knob forward or backward, as required. Tighten the front knob firmly, but avoid overtightening.

The set screw behind the front knob can be used to limit the rearward motion of the toe, allowing you to open the mouth to remove wood chips and then return the toe exactly to where it was.

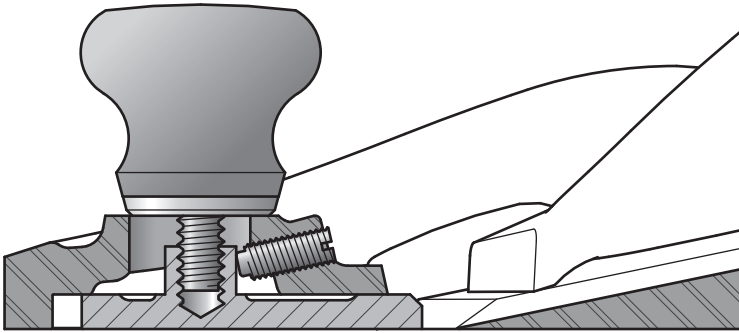

Figure 3: Mouth adjustment.

Cutting Rabbets

The size of the rabbet to be cut is controlled by determining the width (A) with the fence setting and working to the desired depth (B).

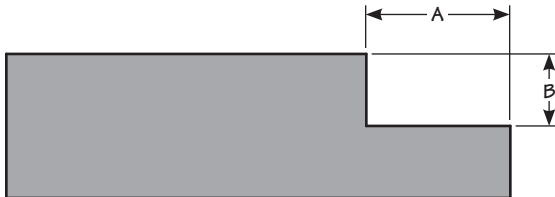

Figure 4: Rabbet dimensions.

Setting the Fence

The width of the rabbet is determined by the fence setting. Loosen the fence locking knob and slide the fence until the distance from the face of the fence to the outside edge of the blade is equal to the required rabbet width. Retighten the fence knob. Maximum width of 1½" when using the entire blade.

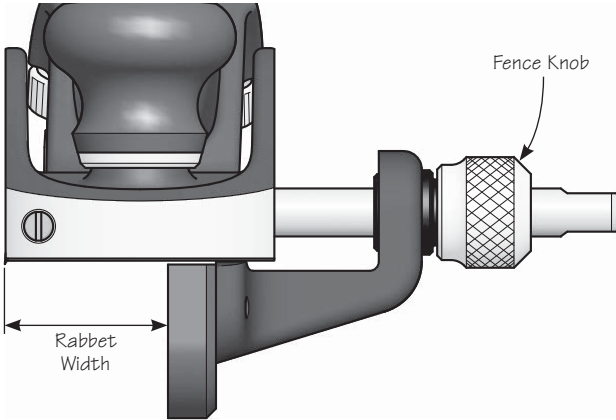

Figure 5: Setting the fence.

Setting the Scoring Blade

The scoring blade (or nicker) is used when working across the grain. The circular blade is attached off-center to an axle, allowing the cutting depth to be adjusted by rotating the blade and axle. (It can also be shifted to a neutral position when it is not required.) To rotate the axle, you must first release the locking screw that holds it in position; it is located in the hole on the front of the plane. Once the scoring blade is in the desired position, retighten the locking screw.

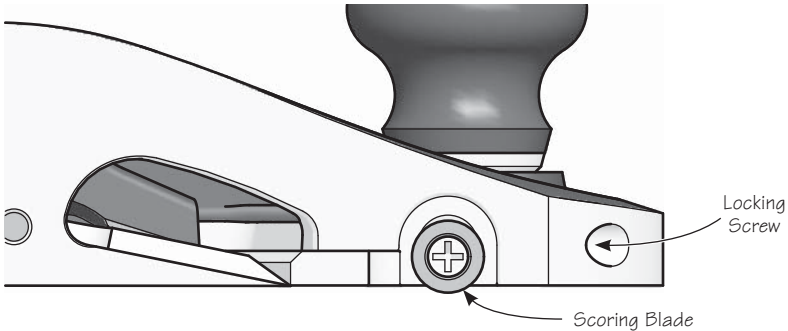

Figure 6: Setting the scoring blade.

The outside (or cutting) edge of the scoring blade must extend just beyond the side of the plane and be aligned with the corner of the blade. To adjust the scoring blade relative to the side of the plane, loosen the fence locking knob and remove the fence. Unscrew and remove the fence rod. Loosen the scoring axle locking screw. Insert a small-slot screwdriver through the fence rod hole to access a slotted set screw that establishes the position of the scoring blade relative to the side of the plane. While pressing the scoring blade and axle in against the set screw, turn the set screw clockwise or counterclockwise as required, until the scoring blade is positioned just proud of the side of the plane. Once the position of the scoring blade is established, retighten the locking screw and reverse the steps to replace the fence rod and fence.

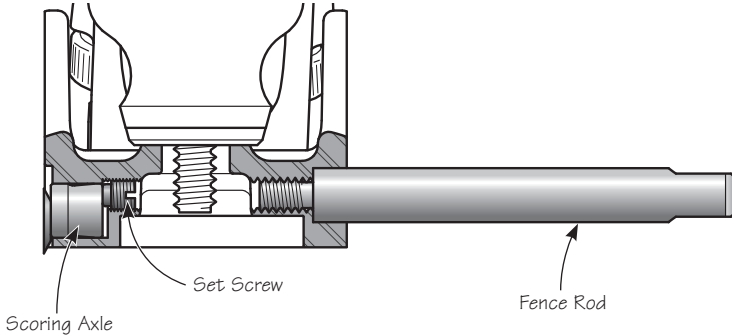

Figure 7: Scoring blade position.

Blade Sharpening

The skew block plane blade has a 15° skew and is ground with a 25° bevel. The face of the blade is lapped. Additional sharpening need only involve honing a small micro-bevel. Since the blade is used bevel up, and the bed angle is 12°, the effective cutting angle is 37°.

The 25° blade bevel is ideal for fine trimming work on end-grain softwood and some hardwoods. Ring-porous hardwoods such as oak may require a 30° bevel to prevent blade edge failure. Simply hone a micro-bevel to the required angle.

Note: The Veritas Skew Registration Jig (05M09.03) for use with the Veritas Mk.II Honing Guide (05M09.01) includes a setting for 15°.

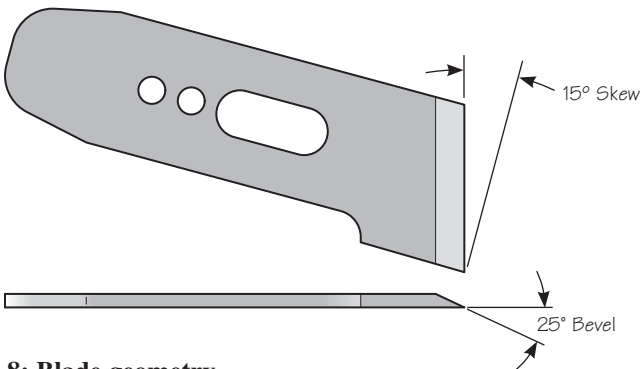

Figure 8: Blade geometry.

The scoring blade will also need to be resharpened over time. Remove the securing screw, then the blade, and lap the face of the scoring blade on a stone.

Auxiliary Fence

For cutting some rabbets, such as one where the depth is much greater than its width, you can add a larger auxiliary fence to better register the plane to the workpiece. Simply make a wooden fence, as plain or fancy as you wish, and attach it using #8-32 machine screws into the tapped holes in the machined fence body. Larger fences may be made $\frac{3}{4}$ " thick and attached using the #8-32 $\times \frac{7}{8}$ " long machine screws included with the plane.

Care and Maintenance

The body of this plane is ductile cast iron and comes treated with rust preventative. Remove this using a rag dampened with mineral spirits. Clean all machined surfaces.

We recommend that you initially, then periodically, apply a light coat of silicone-free paste wax to seal out moisture and prevent rusting (as well as act as a lubricant for smoother planing). Wipe off any wood dust from the surfaces that you will be waxing, apply a light wax coating, let dry, then buff with a clean soft cloth. At the same time, the solvents in the wax will remove any harmful oils left from your fingers that can lead to corrosion.

If storage conditions are damp or humid, the plane should, in addition to the treatment outlined above, be wrapped in a cloth or stored in a plane sack. This precaution will also guard against dings and scratches.

Accessories

- 05P76.02** A2 Blade, Right
- 05P76.52** O1 Blade, Right
- 05P76.72** PM-V11[®] Blade, Right
- 05P76.60** Wood Fence, Right
- 05P77.02** A2 Blade, Left
- 05P77.52** O1 Blade, Left
- 05P77.72** PM-V11[®] Blade, Left
- 05P77.60** Wood Fence, Left
- 05N35.11** Replacement Scoring Blade
- 05P76.62** Optional 3 1/2" Long Fence Rod